

CustomSound™ CS810 2-Way In-Ceiling Loudspeaker

psb
SPEAKERS



This superb group of architectural speakers embody over 40 years of cutting-edge research in the field of acoustics and loudspeaker design. Musical, refined, and nearly invisible, these speakers can create a beautiful ambience, even in larger spaces. Because their sonic signature is identical to other PSB speakers, the CS series can integrate perfectly as part of home theatres or as the soundtrack of the connected home. Since PSB has in-room, on-wall, outdoor, in-wall and in-ceiling designs at many different price points, it makes it easy to specify an audio system that you know will turn out right, be easy to specify and install, and will absolutely thrill even your most discriminating clients.

There are seven models in this series, and all feature frameless magnetic grilles with invisible scrims. Both round and square grilles are provided (CS605, CS805 only have round grills), simplifying and reducing your inventory requirements. Each model features an improved, simple, foolproof mounting system using heavy duty doglegs. Cutting templates are included. Pre-construction brackets and back-cans are also available.

CS810 2-way In-Ceiling Speaker

Featuring PSB's trademark carbon-filled polypropylene 203mm (8") woofer, this speaker has a warm and balanced sound with plenty of power handling thanks to the high temperature voice coil. The 25mm (1") aluminium dome tweeter, another proprietary PSB driver, is concentrically mounted and features a carefully engineered Wave Guide and ball-joint pivot mount assembly. This allows the tweeter to go lower in frequency, creating a perfect blend with the woofer in the cross-over region, and allows the tweeter to be aimed toward the listening position for enhanced musical imaging. Adjustment for the level of the tweeter allows you to 'dial in' the upper frequency response of the speaker and its acoustic environment after installation to achieve the most musical balance for every room.

- 203mm (8") 2-way in-ceiling flush mount speaker
- Proprietary Imagine carbon-filled polypropylene cone with steel basket
- Proprietary 25mm (1") titanium dome tweeter
- Aimable tweeter angle adjustment (ball-joint)
- Precision crossover network for smooth wide-band response
- Dual position switch for tweeter level
- High strength doglegs for easy installation and removal
- Includes both round and square magnetic frameless grilles

CustomSound CS810 2-Way In-Ceiling Loudspeaker

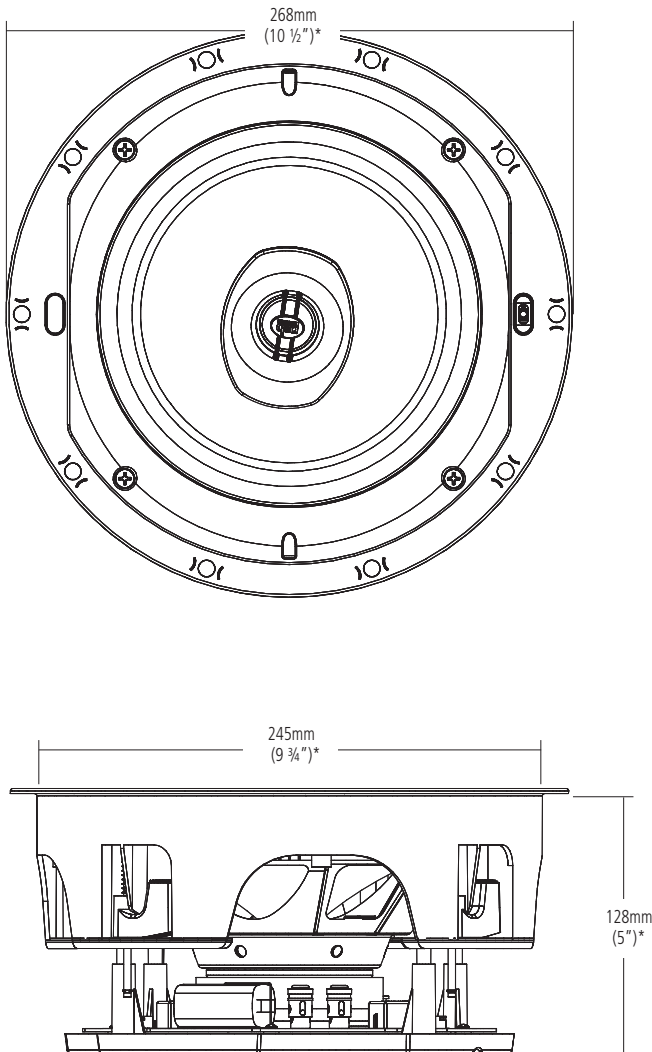

Frequency Response (Anechoic Chamber)

On Axis @ 0°±3dB 48-20kHz

Sensitivity (1W (2.83V) @ 1M, IEC-Filtered pink noise, C-weighted)

Anechoic Chamber 85dB
Listening Room 87dB

Impedance

Nominal 6 Ohms
Minimum 4 Ohms

Input Power (RMS, Clipping <10% Time)

Recommended 10-100 Watts

Acoustic Design

Tweeter (Nominal) 25mm (1") Titanium dome with ferrofluid
Woofer (Nominal) 203mm (8") Stamped Steel Basket
Black Polypropylene Cone
Rubber surround
Crossover 3.1kHz LR4
Design Type Open back
EQ Adjustment Tweeter switch

FINISH/CONSTRUCTION

Back Frame ABS
Grille Material Steel; Perforated with white scrim
Grille Type Frameless
Connectors Gold-plated, Spring Loaded, 12AWG

Size (W x H x D) (Gross Dimensions)

Mounting Depth 128mm (5")*
Cutout Diameter 245mm (9 3/4")*
Grill Round 272mm (10 3/4")*
Grill Square 272mm x 272mm (10 3/4" x 10 3/4")
Both round and square grill supplied

* Non-metric measurements are approximate.

REAL SOUND for REAL PEOPLE
www.PSBspeakers.com